



SlowStop® Type 2 Modular FlexRail (SS-T2Y-100-GRS)



45 Degree Impacts

MASS (KG)	1000	2000	3000	4000	5000	6000	7000	8000	9000	10000
SPEED (KPH)										
3.0										
3.5										
4.0										
4.5										
5.0										
5.5										
6.0										
6.5										
7.0										
7.5										
8.0										
8.5										
9.0										
10.0										

No Damage / Negligible Damage
Will Stop / Potential Damage to Guard
May Stop / Damage to Guard

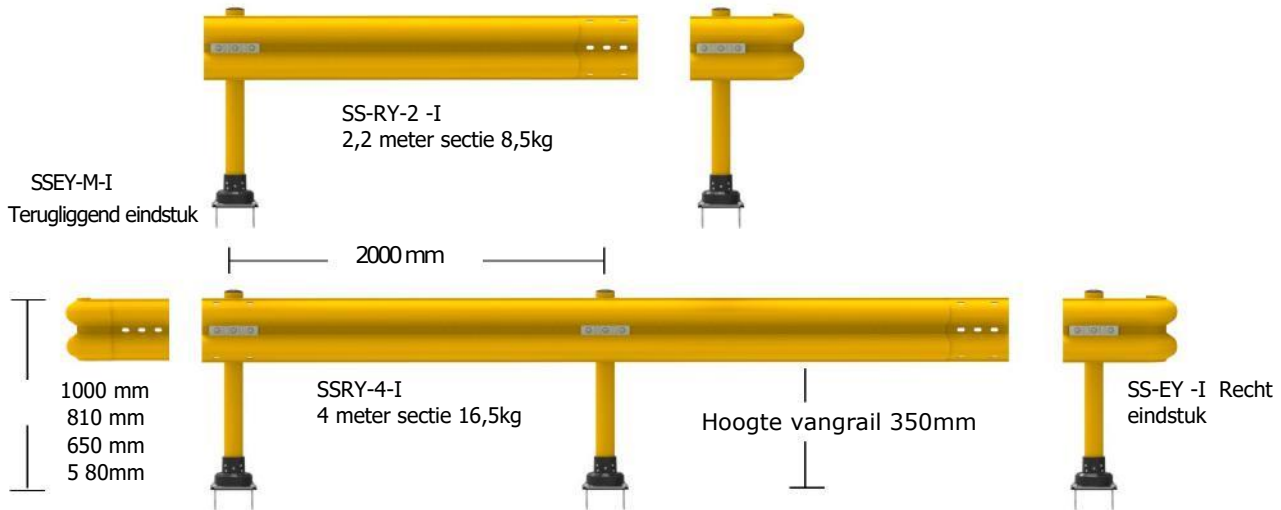

SPECIFICATIES

- Inclusief SlowStop® vangrailpaal Type 2
- Vangrail Break Strength: 110 kN
- Stopping Power Rating 17.214 Joules- 45° Rail Impact
- Max uitbuiging: 71 cm tot breuk
- Temperature Rating: -40°C tot 115°C
- Verkeersgeel (RAL 1023) door en door
- Geenbuigmal nodig voor bochten min. R(5 meter)
- Hoogte op klantwens mogelijk adv. 580/680/810 mm

TOEPASSINGEN

- Industriële afscherming
- Infrastructuur bescherming
- Voetgangerspad in productiebedrijven afbakenen
- Machinebescherming
- Magazijn inrichting
- Kantoor bescherming
- PC werkplekken in warehousing
- Parkeerplaatsen afschermen.



4955 Stout Dr. • San Antonio, TX 78219
 TEL: +1 (210) 736 4477 • FAX: +1 (210) 734 6448
 Email: info@aanrijdbeveiliging-slowstop.nl

